

AR / 240

gives you

800

channels in the palm of your hand



**...the world's
first synthesized 800
channel hand held
transceiver**

SPECIFICATIONS

Frequency Coverage: 144 to 148 MHz
Channel Spacing: Every 5 KHz
Power Requirements: 9.6 VDC
Current Drain: 17 ma-standby 400 ma-transmit
Batteries: Ni-cad battery pack included
Antenna Impedance: 50 ohms
Dimensions: 40 mm x 62 mm x 165 mm (1.6" x 2.5" x 6.5")
RF Output: Better than 1.5 watts
Sensitivity: Better than 5 microvolts

SUPPLIED ACCESSORIES

Telescoping whip antenna, ni-cad battery pack, charger.

"A staggering technical achievement"; "How can they get it into such a small size"; "Outperforms any rig I've ever had"; these are typical of the comments made by amateur radio operators after seeing and using the remarkable AR240 2 metre FM handheld transceiver. What does it mean to you? Well, at last you can really take your amateur radio with you, anywhere you want to go, because in this handheld unit, you have a complete synthesised 2 metre FM transceiver covering 144.000 - 147.995 KHz in 5 KHz steps. Also included are + and - 600 KHz repeater shifts and a crystal controlled tone burst unit.

The AR240 design is based on a very advanced PLL synthesiser which generates the local oscillator signal for a single conversion transmitter with an outstandingly clean signal and an output power well in excess of the 1.5Watt specification. Transmit audio is penetrating and easy to copy, helped in no small measure by the electret capacitor microphone built into the AR240. Tone burst for repeater access is generated by a 7.168 MHz crystal which is divided in a custom IC to give 1750 Hz literally "rock steady" tone.

The AR240 receiver is the equal of many full size base stations; samples measuring out at 12 dB SINAD for less than 0.2 microvolts. The receiver is fitted with a suffix "G" filter which as you will know, is perfectly matched to current or future European deviation standards. The recovered audio is exceptionally good, even on weak signals and the internal loudspeaker produces more than enough output for use anywhere. An external loudspeaker socket is provided should you wish to use either an earphone, or larger speaker unit.

Operation of the AR240 is very simple indeed. You simply select the frequency required on the direct reading frequency decade switches, switch on the transceiver, pull out the telescopic whip and speak into the microphone. Repeater shift is selected by a switch on the rear panel and tone burst activated by a secondary button on the PTT bar.

If you are considering a handheld 2 metre unit, there is nothing to compare with the AR240. Other units which are bulkier and heavier usually offer only six crystal controlled channels.

ADR AR240

RX CT J-020-01

2SC1674 2SC1070(R)

2SC1674

2SC1675

2SC1675

BANDPASS
TUNING

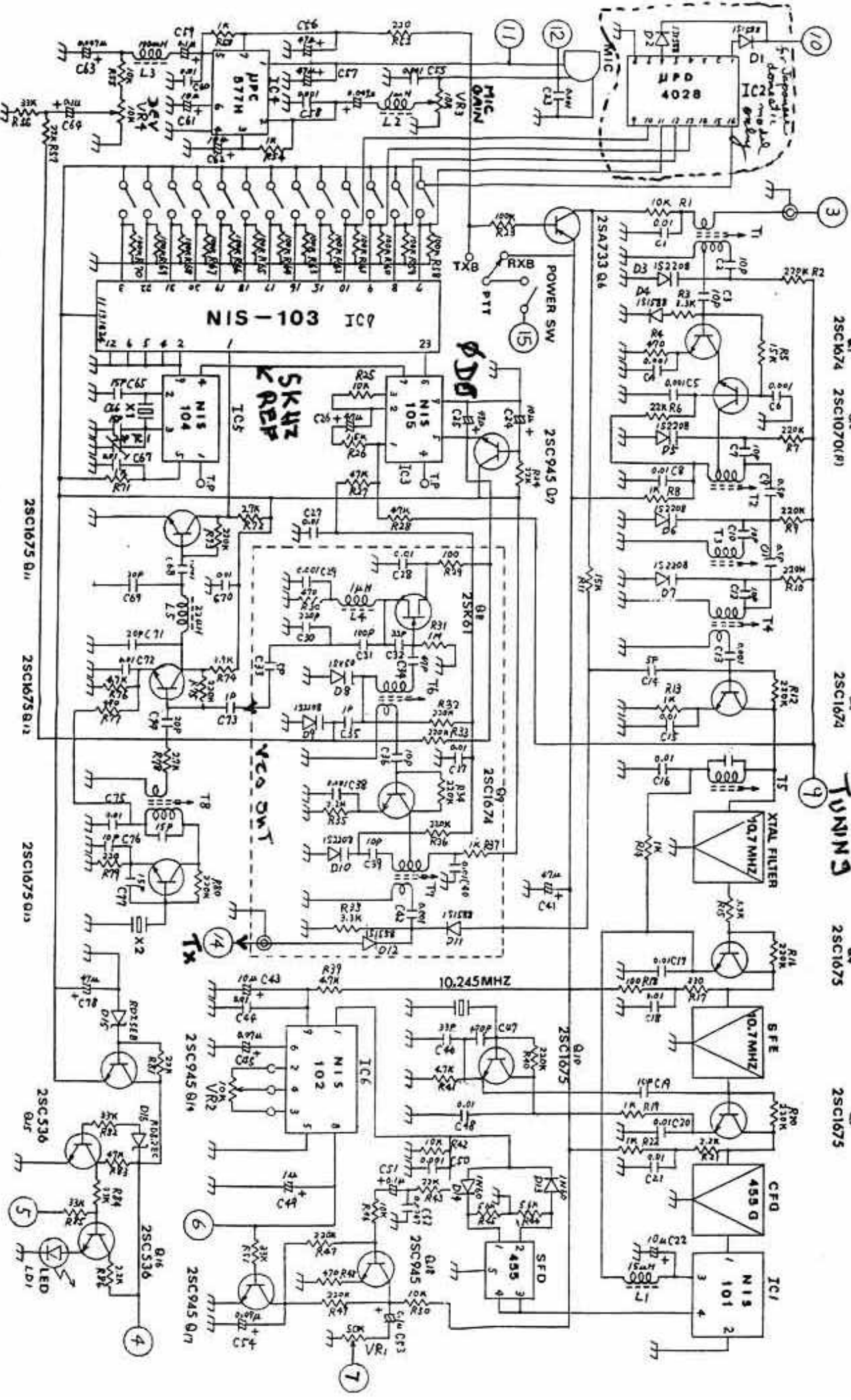

J-020-02

25C2221 Q14

25C2026 Q33

25C2026 Q31

25C2026 (1,1)

25K01 Q19

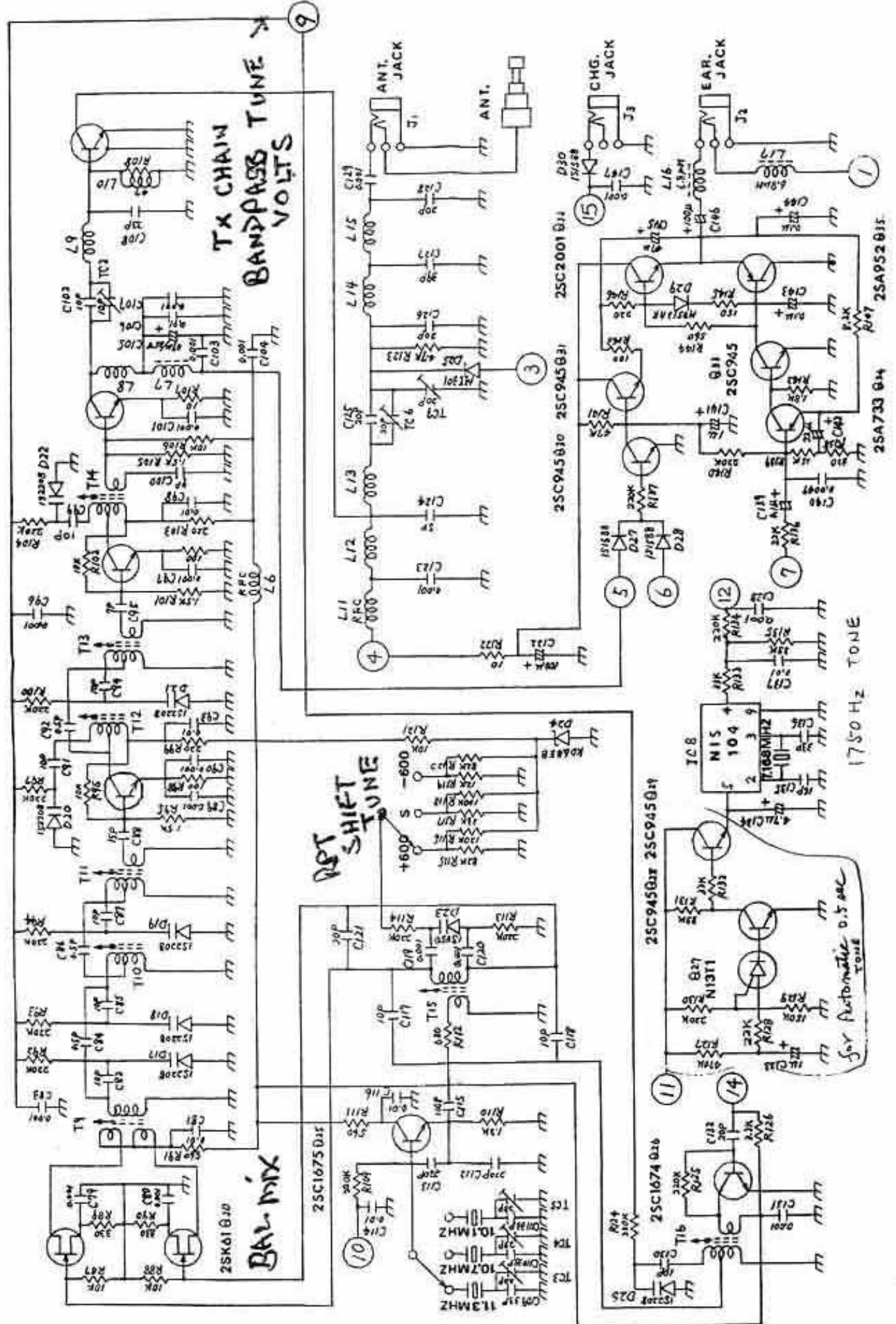

TX CHAIN
BANDPASS TUNE
VOLTS

RPT
SHIFT
TUNE

1750 Hz TONE

For Automatic 0.5 sec
TONE

9

4

3

5

6

7

12

11

14

1

2

3

4

5

6

7

8

9

10

11

12

13

14

15

16

17

18

19

20

21

22

23

24

25

26

27

28

29

30

31

32

33

34

35

36

37

38

39

40

41

42

43

44

45

46

47

48

49

50

51

52

53

54

55

56

57

58

59

60

61

62

63

64

65

66

67

68

69

70

71

72

73

74

75

76

77

78

79

80

81

82

83

84

85

86

87

88

89

90

91

92

93

94

95

96

97

98

99

100

101

102

103

104

105

106

107

108

109

110

111

112

113

114

115

116

117

118

119

120

121

122

123

124

125

126

127

128

129

130

131

132

133

134

135

136

137

138

139

140

141

142

143

144

145

146

147

148

149

150

151

152

153

154

155

156

157

158

159

160

161

162

163

164

165

166

167

168

169

170

171

172

173

174

175

176

177

178

179

180

181

182

183

184

185

186

187

188

189

190

191

192

193

194

195

196

197

198

199

200

201

202

203

204

205

206

207

208

209

210

211

212

213

214

215

216

217

218

219

220

221

222

223

224

225

226

227

228

229

230

231

232

233

234

235

236

237

238

239

240

241

242

243

244

245

246

247

248

249

250

251

252

253

254

255

256

257

258

259

260

261

262

263

264

265

266

267

268

269

270

271

272

273

274

275

276

277

278

279

280

281

282

283

